

The Four Wheel Independent

2019
May

Inside This Issue:

C.P.C.C. Officers	
About CORSA	
Our Next Meeting	2
2019 International CORSA Convention	
National Apple Harvest Festival Car Show	
Latimore Car Show	3
Capitol City Cruisers Car Shows	
V-P Ramblings	4
Upcoming Events	5
Car for Sale	
May Birthdays	6
Happy Anniversary	
The Preventive Maintenance Series	7
Treasurer's Report	
Welcome New Members	8
Corvair Cooks Corner	9
Secretary's Report	
Thank You	10
Help Wanted	



To all our readers who have served or is serving our country.

You are our heroes

You've made so many sacrifices

... for our country

... for our families

... for each of us individually

We all want to take a moment to extend to you our heartfelt "Thanks" for all you have done and for all that you do.

God Bless You,

CPCC Members

C.P.C.C. OFFICERS
PDF Compressor Free Version

OUR MEETING NEXT

Tuesday, May 14th at Hoss's Restaurant in York, PA



Do we have your birthday and wedding anniversary dates? We'd love to share your special days with other club members.

Send information to Carol at lcl@pa.net.

President

JOHN Berkheimer
 403 Dart Drive
 Hanover, PA 17331
 (717) 632-5617
 Email: jhbmail1@comcast.net

Vice-President

John Johnson
 550 Gross Road
 Fawn Grove, PA 17321
 (717) 456-5139
corvair@zoominternet.net

Secretary

Earl Holmes
 1511 Hicks Drive
 Dauphin, PA 17018
 (717) 991-7341
 Email: earlzgames@comcast.net

Treasurer

TBD

Board Members

Linda Enfield
 11925 High Point Road
 Felton, PA 17322
 (717) 244-7181
 Email: jte448@zoominternet.net

Joe Darinsig
 1751 Chesley Road
 York PA 17403-4001
 (717) 668-4414
joedarinsig@yahoo.com

Newsletter/Web Editor

Carol Trimper
 30 Wheaton Drive
 Littlestown, PA 17340
 (717) 451-4290
 Email: lcl@pa.net

Club Photographer

Lou Trimper
 30 Wheaton Drive
 Littlestown, PA 17340
 (717) 451-4289
 Email: lcl@pa.net

The Corvair Society of America (CORSA)



"Founded in 1969 by and for those who still appreciate the Corvair automobile"

Central Pennsylvania Corvair Club strongly encourages all members to become members of the Corvair Society of America (CORSA). Anyone with a fondness of the Corvair automobile will benefit from CORSA membership. In addition, we will all benefit by maintaining a strong national presence to lobby our interests and organize our collective purposes.

PLEASE do not overlook the potential value of a CORSA membership. Try it out. Your first year will cost only \$45. If you share our enthusiasm for these superbly engineered and styled cars, why not join our Society today? Domestic dues are only \$45 for 1 year/ \$90 for 26 months (two months free!) We are sure you will find it a worthy and rewarding investment!

Visit:

<https://www.corvair.org/index.php/membership/join-register-or-renew> to register online.

CORSA
 P.O. Box 68
 Maple Plain, MN 55359
 (630) 403-5010
www.corvair.org



2019 CORSA International Convention
St. Charles, IL - July 23-27, 2019

Go to:
https://www.corvair.org/index.php?option=com_civicrm&task=civicrm/event/info&Itemid=445&id=300 for additional information.

How would the Club like to attend this as a group?
PDF Compressor Free Version
October 5-6 & 12 & 13, 2019



Antique Automobile Registration Information

1. The 55th National Apple Harvest Festival will be upon us before you know it. We are looking forward to another great year. Please review the following guidelines for displaying your vehicle at the **2019 festival**.

Registration: This year's registration fee will be \$10.00 (\$11 if purchased online) per antique auto. This fee will cover any day or days you wish to attend the festival. Your registration includes free admission for 2 people in the car. If there are more than two people in your auto, the additional people will be charged \$5.00 per person at the gate. Please do not bring cars newer than **1980** and cars must be in show quality condition. Due to limited space, **we can only accept 250 cars per festival day**. All autos attending the display must be pre-registered. Registrations are accepted on a first come first serve basis. **All registrations must be received by September 1st** due to mailing confirmation letters. Display cars must be present on the festival grounds by 11:00 a.m. daily or they will not be admitted. Please plan for the festival traffic so you arrive at the festival by 11:00 a.m. (Worship services are held in Apple Auditorium at 10:00 a.m. each Sunday). No tents or canopies permitted in display area. Smoking is permitted in designated areas only.

2. **Directions:** You will receive a registration confirmation letter. **You must bring this confirmation letter with you every day that you attend the festival.** As you enter the festival grounds the fire police will direct you to the Antique Auto gate. After checking in with the Antique Auto staff you will be given an information packet and further direction to park your vehicle.

3. **Awards:** Awards will be presented daily at 2:45 p.m. under the Antique Auto display tent. After the completion of the awards presentation, the gate will be reopened for autos to leave the festival grounds. All autos need to remain on display from 11:00 a.m. through the awards program.

4. **Questions:** If you have any questions please contact the National Apple Harvest Festival Office (717-677-9413 or festival@appleharvest.com). One of the festival secretaries will answer your questions or you may leave a message for one of the Antique Auto committee members.

Go to: <https://www.appleharvest.com/antique-automobiles.html> for a printer friendly version of the Antique Auto Registration Contract and for additional information.

Please mail your registration contract and check or money order made payable to:

National Apple Harvest Festival
Attn: Antique Auto Committee
P.O. Box 38
Biglerville, PA 17307

Lots of cars, food, arts & crafts and many other activities throughout the day.

Gettysburg Region AACA



44th Annual



Latimore Car Show

Classic ~ Antique ~ Street Rod ~ Muscle Car
All Years Auto & Truck Show

Flea Market & Car Corral

SATURDAY JUNE 8, 2019

GATES OPEN 7:00 A.M.

Breakfast and Lunch will be available.



Latimore Valley Fair Grounds

Eastern Museum of Motor Racing



314 Latimore Valley Rd., York Springs, PA 17372

Show Contact: Bob Shultz (717) 766-0457 or Don Barlup (717) 582-3209

Website: www.gettysburgregion.aaca.org or Gettysburg Region AACA on Facebook

Registration Forms on Reverse Side

Capitol City Cruisers  **1st SATURDAY**
at the
Roadhouse
Capitol City Cruisers

are HOSTING a MONTHLY CRUISE in 2019

APRIL thru OCTOBER **4 to 7 pm**



1031 Eisenhower Blvd
Harrisburg, PA 17111

Music by
Harry
Loranzo



Café is open!

APRIL 6th MAY 4th JUNE 1st JULY 6th
AUGUST 3rd SEPT. 7th & OCTOBER 5th

Rain Date will be the 2nd Saturday

DOOR PRIZES FREE REGISTRATION

Call Charlie Roberts at 717-805-1650

or Rod Murray at 717-579-5440

"Like" us on Facebook!

PDF Compressor Free Version

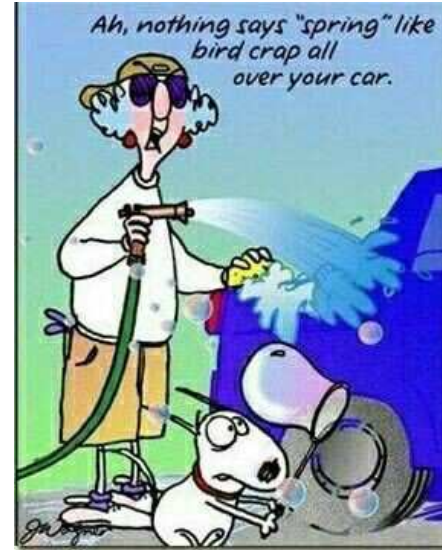

TRIVIA

Weird things about the name Corvair:

Your name in reverse order is *Riavroc*. A random rearrangement of the letters in your name (*anagram*) will give *Caovrir*. How do you pronounce that?

V-P Rambling

Submitted by
John Johnson



Spring, is it finally here? We haven't had snow since March, but tornado warnings, severe thunderstorm warnings and flood warnings have been the norm in April. Mother Nature has got to give us a break. I have yet to get either of the Corvairs out this spring. I am hoping to drive one to Hanover on April 27th to the tech session. Since it is April 20th writing this article, hopefully, I can talk about the great time I had on the 27th in a future newsletter. It looks as if we are going to have an active year as a Club. Road trips and cruises have always been my favorites. As far as Car Shows, don't forget the Markets of Shrewsbury host a great show the 4th Friday of the month. I usually try to go, if you get a chance, give me a call and we can meet before going into the show. That guarantees we can

park together. There are generally 600+ cars in attendance any given Show date.

Switching gears, I want to talk about the changing Corvair auction market. The latest Barrett-Jackson auction had several of note. A 1962 Rampside 4 speed went for \$70,000!! A 1964 Monza powerglide convertible 100 hp and a '66 Monza powerglide convertible with air, each brought \$38,000!!! Yet a beautiful '64 Spyder Convertible Yellow with black interior only brought \$16,500. All the Corvairs brought \$12,000 minimum no matter coupe or convertible. The Corvair market is definitely heating up. Another item of interest happened when I was surfing the internet. There was an article about the first "Cannonball Run". As I was

checking out the vehicles participating, there sat a Greenbrier. Who would have guessed that! I need to do some research to see the year and whether the Greenbrier finished. There was a program on the Motor Trend channel that featured a Greenbrier. It is owned by a photographer who travels, mostly the West, taking and selling photos to sell to advertisers and magazines. He said he puts 60,000 miles on the van each year and has not had any major problems. The van carries his equipment as well as providing somewhere to sleep when the need arises.

Enough rambling for this month. Remember to keep your eyes open to the "car channels" as I can guarantee you will see our Corvairs taking their long-deserved bows.



MAY 2019

May 10: Cruise Night, The Markets at Shrewsbury, Glen Rock, PA.

May 11: AACA Gettysburg Region Spring Tour, Details in upcoming Gazette - contact is Don Barlup - 717-582-3209.

May 14: CPCC Regular Monthly Meeting at Hoss's Restaurant in York, PA.

May 17-19: Carlisle Import & Performance Nationals, Carlisle, PA Fairgrounds/Carlisle Expo Center.

May 18: CPCC "Possible" trip to Washington County Rural Heritage Museum.

May 24: AACA Gettysburg Region Ladies' Day Car Show, Tranquility Salon reservations are due by **March 18** - contact is Pat Shaffer - 717-258-4964.

May 24: Cruise Night, The Markets at Shrewsbury, Glen Rock, PA.

May 31-June 2: NSRA 46th ANNUAL STREET ROD NATIONALS EAST National Street Rod Association at the York Expo Center (334 Carlisle Ave. York, PA 17404). See over 3,500 Street Rods, Street Machines, Custom Cars and Trucks and Specially Vehicles all 1989 and older, plus a huge display of auto manufactures exhibits. Games, Live Entertainment, NSRA Super Prize Giveaways, lots of great food and fun for the whole family.

May 31-Jun 2: Carlisle Ford Nationals Carlisle Events from Thu.-Sat. 7:00AM-7:00PM, Sun. 9:00AM-12:00PM at the Carlisle PA Fairgrounds. An all Ford, Lincoln, Mercury show field, midway, swap meet and car corral. Fords, new and old, with special guests, indoor displays of concepts, customs and historically-significant cars and trucks; test drives by Ford Motor Company, a burnout competition, activities for the kids, industry guests, giveaways, autocross for all skill levels and club gatherings.

JUNE 2019

June 8: AACA Gettysburg Annual Region Car Show Save the date!

June 11: CPCC Regular Monthly Meeting at Hoss's Restaurant in York, PA.

June 15: Carlisle Summer Sale, Carlisle Expo Center, Carlisle, PA (Auction Sat. ONLY by Carlisle Auctions).

June 21-23: Carlisle Chevrolet Nationals, Carlisle, PA Fairgrounds/Carlisle Expo Center.

June 28: CPCC Cruise Night, The Markets at Shrewsbury, Glen Rock, PA.

JULY 2019

July 7: AACA Gettysburg Region Picnic Details in upcoming Gazette Newsletter.

July 12-14: Carlisle Chrysler Nationals The largest Mopar event in the world features over 2,700 vehicles from all eras of the Chrysler brand. Classics, muscle cars and high performance new models are all showcased at this Mopar-lover's paradise.

July 14: Run With the Angels Car Show Road Angels from 9:00AM-3:30PM at Route 313 and Cold Spring Creamery Road, Doylestown, PA. Show is on the Moravian Tile Works grounds, 1/2 mile east of Route 611. Trophies, Door prizes, Flea market, and Awards. All Street Rods, Customs, Muscle Cars, Trucks, and Antiques welcome!

July 20: CPCC Annual Picnic at Berkheimer's home. Mark your calendar and Save The Date!

July 23-28: 2019 CORSA International Convention The End was the Beginning in St. Charles, IL

July 26: Cruise Night, The Markets at Shrewsbury, Glen Rock, PA.

July 27: Hanover PA Dutch Day Festival, Hanover Square, 8am—4pm, (cars should arrive early), German-themed festival featuring 300 food and hand-made craft vendors, German entertainment, Antique Car Show and kids carnival, Free Admission, Held Rain or Shine. This festival is always a hit with people and there is something for everyone!

AUGUST 2019

August 15-17: Littlestown PA Good Ole Day Festival, held at Crouse Park from 8am-4pm with Arts, Crafts, Food Vendors, Car Show, Music, and much more.

August 2-4: Carlisle Truck Nationals, Carlisle, PA Fairgrounds/Carlisle Expo Center.

August 13: CPCC Regular Monthly Meeting at Hoss's Restaurant in York, PA

August 17: Glenview Alliance Church Cruise Night Car & Bike Show from 4-8 pm. Rain Date August 24 at Glenview Alliance Church, 10037 Susquehanna Trail S., Glen Rock, PA 17327, Free admission, free food, trophies awarded.

August 22-25: Corvettes at Carlisle, Carlisle, PA Fairgrounds/Carlisle Expo Center.

August 23: Cruise Night, The Markets at Shrewsbury, Glen Rock, PA.

SEPTEMBER 2019

September 21: CPCC Corvair Day at AACA Museum Hershey PA. Rain Date, Sunday, September 22, 2019.

September 27: Cruise Night, The Markets at Shrewsbury, Glen Rock, PA.

continued on Page 6



September 27-29: 10th Annual North East Shelby Meet at Lehigh Valley Pennsylvania SAAC A weekend of great cars, fun people, and things to do with your Shelby car and friends!

OCTOBER 2019

October 2-6: Fall Carlisle, Carlisle, PA Fairgrounds/Carlisle Expo Center (Auction Thurs/Fri/Sat by Carlisle Auctions).

October 8: CPCC Regular Monthly Meeting at Hoss’s Restaurant in York, PA.

October 9-12: Eastern Division AACA National Fall Meet – Antique Automobile Club of America at Hershey, PA on the grounds and parking lots surrounding Hershey Park and The Giant Center. Events Include: Car Corral, Flea Market, Sat. Car Show, Ladies Luncheon, High Wheeler Contest, Race Car Condition Run, Judging School, AACA Juniors, Talent Show and Old Time Movie Night.

October 12: Trunk or Treat at The Shrewsbury Markets, Glen Rock, PA.

October 19 & 20: CPCC “Possible” Overnight Trip to Penn College Williamsport PA. Read President’s Message on Cover page for additional information.

October 25: Cruise Night, The Markets at Shrewsbury, Glen Rock, PA.

NOVEMBER 2019

November 2: Kiddies Toy Cruise, 11am-3pm, The Markets at Shrewsbury, Glen Rock, PA.

November 12: CPCC Regular Monthly Meeting at Hoss’s Restaurant in York, PA.

If you would like to add an Upcoming Event, please email to Carol at ldl@pa.net.

CAR FOR SALE

1964 Corvair Spyder Convertible

4-Speed.
 Red exterior with white top and interior. No rust.
 Older restoration.
 Looks and drives good.
 New tires.
 \$18,500.00.

If interested or would like more information, please call Dale at (717) 698-2934.



Steve & Susan Hooper
May 20th

Lou & Carol Trimper
May 20th

Duane & Jacquie Aldrich
May 27th

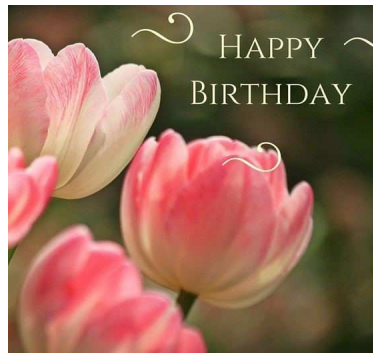

Susan Hooper May 05

Earl Holmes May 17

Betty Hash May 23

Andrea Thompson May 27

Rich Heisler May 28



FDE Compressor Free Version The Preventive Maintenance Series

By Mike Dawson

Tales of Two Recent Maintenance Issues

1. Clutch pedal goes to the floor-literally!

One of our members, Linda Reece, was driving in Harrisonville with her grandchildren tucked into her 1964 Spyder convertible when the clutch pedal went to the floor and then the entire pedal and arm assembly fell out *onto* the floor. After driving without a clutch to a safe spot, she called me with the errant part in her hand. After I explained what had happened she contacted friends and a tow truck and had the Spyder brought to my place. This particular trauma is only common to manual transmission early model cars but it is a combination of marginal welding at the factory, cycles of use and stiffness of the pressure plate and return spring. The support that is bolted under the dash has a tube welded to it that has two plastic bushings for the clutch pedal to pivot on. If you have an early model car with manual transmission I would recommend heading off the possible failure by initiating a preventive operation.

At first examination it looks like you cannot remove the assembly without taking out the steering column but with a little twisting (you and the column) you can accomplish removal and installation. The first step is to remove the clutch return spring and unhook the adjusting rod from the lever at the rear, so you have slack in the cable. Next, since there are plastic bushings at the welding site, you must unbolt the assembly (3 bolts), remove it with the pedal stop and then remove the snap ring and two bushings. If the tube with the bushings has already bent slightly, be sure and use a square to align it before welding. Hook the clutch cable clevis back on the pedal arm before bolting the bracket tight.



2. Failed fuel pump repairs itself overnight?

Another member, Sherman Rutherford, was on his way to the Thunder in the Valley Speedway for our club gathering when

he was spotted in a parking lot with both lids up. When I arrived Sherman already had a gas line off and had determined that no gas was being delivered to the carburetors. The quick diagnosis by both of us was that another mechanical fuel pump had expired. Once removed, I tried pumping the stem on the pavement but no suction was available so a new pump was installed and off to the racetrack we went. As the club met in the shade of the bleachers, we discussed fuel pumps and I took Sherman's dead pump apart. There was no evidence of loose valves, ruptured fabric, or rust pieces, so I reassembled it and tried stroking it again. No suction. It came apart again and this time (with reading glasses) I noticed that the edge of the rubber/fabric valve was up off of the seat slightly. I used a pen to push it back down but it popped back up. I thought it must have dirt under it and turned my attention to racecars and cold beverages. I would solve the mystery later.

The next morning I returned to the fuel pump valve body and discovered that overnight the open valve had closed with out any help. I reassembled the pump and it worked perfectly. My first suspect was that the valves were warping due to high heat and gas additives. After Sherman indicated he purchased premium fuel at Casey's I am speculating that our culprit is 15% ethanol. After talking to several folks about the issue I think that Casey's adds another 5% ethanol at the terminal and uses the "splash method" of mixing to provide their premium grade at the pump. I asked the manager at our local Casey's about their premium fuel but received a non-answer for my trouble. A shop here in Belton says that they do a lot of older Chrysler vehicle valve jobs because the exhaust valves burn from too much ethanol. I personally have never used the premium that has ethanol but using the regular grade with 10% has never caused any problems in my cars other than hot idle or hot restart issues, which I have largely solved. There are several stations in the metro area that sell premium with no ethanol – I would recommend spending the additional dollars, your Corvair will probably reward you with better service.

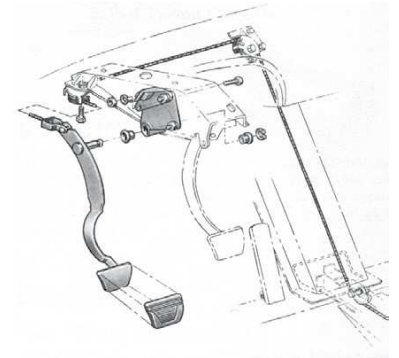

Taken from hacoa.org August 2015 VAIRCOR newsletter, Vol 51, Issue 8.

Treasurer's Report for February 2019

Acting Treasurer
JOHN Berkheimer



Beginning Balance		\$2,909.67
Deposits:		
Dues	16.00	
50/50	18.00	
Expenses:		
Total Deposit		34.00
Balance:		\$2,943.67



Lot #F237 1966 Chevrolet Corvair Yenko Stinger 2-Dr. Hardtop; S/N 107376W132267; White, Blue stripes/Black vinyl; With Reserve; Estimate \$65,000-\$100,000; Recent restoration, 2- condition; Hammered Sold at \$200,000 plus commission of 10.0%; Final Price \$220,000. – 164/220hp Stage III engine, 4-speed, dual circuit master cylinder, headlight stoneguards, 13-inch Minilite alloy wheels, National tires, 4-speed, pushbutton radio, Weber 40IDA301 3-barrel carbs, rollbar, Yenko #YS-074. – Sound repaint not wet sanded on the fuel filler cover and scraped off on the engine cover fresh air vent hinges. Clean, orderly engine compartment not overdone. Good chrome, glass and interior. An exceptional Stinger. The engine that's in it is not original, but the original block comes with it. MCACN Concours Gold winner. – Kissimmee couldn't get Yenko Camaros sold for \$200K, but they got \$220K (double the high estimate) for this nearly impeccable Yenko Stinger. That's a thousand dollars per horsepower. A staggering result.



RANDY AND PAULA MARCH
They own a 1964 Convertible (automatic) and a 1964 with a 1965 engine Convertible (4 speed)
Please take a moment at our next meeting to welcome Randy and Paula.



FRANCIS SCOTT KEY ANTIQUE CAR CLUB, INC
Chapter of Sugarloaf Mountain Region of AACA



34th Annual Vehicle Show to Benefit

Fred Co Hospice, Alzheimer's Assoc., & Rose Hill Manor Children's Museum

SATURDAY, AUGUST 17th 2019

(RAIN DATE SUNDAY, AUGUST 18th)

ROSE HILL MANOR CHILDREN'S MUSEUM & HISTORIC PARK

1611 N. Market Street, Frederick, MD

flea market, food, music, Rose Hill Manor tours (fee), WW II re-enactment

Registration: 8:00 a.m. – 12:00 p.m. Longest distance registered vehicle driven award
Voting: 10:30 a.m. – 12:00 p.m. Youngest and Oldest driver registered awards
Awards: Approx. 2:00 p.m. Boy Scouts Choice award
Dash plaques for first 150 vehicles registered FSKACC Best of Show pick
25 Top participant's choice awards

PRE-REGISTRATION/REGISTRATION (Please Print)

Name _____

Address _____

E-mail address (for future show notification) _____ @ _____

VEHICLE INFO		FIRE EXTINGUISHERS SUGGESTED IN VEHICLES	
Year	Make	Model	

Vendor or Car for Sale Space approx. 10' x 15' (Your Tax number) _____

Brief description of merchandise: _____

SUGGESTED DONATIONS Tax exempt 501 (c) (4)
\$10 pre-registration before Aug 10th or \$15 day of show per vehicle or space.

Make checks payable to: FSK Antique Car Club, Inc., Benefit (sorry, no refunds)
Mail check with this form to: Bob Failor, 101 Fairfield Dr., Frederick, Maryland 21702

Info: Ed -301 514-2207 or Skip -240 422-0368 Facebook at: Francis Scott Key Antique Car Club
Fred Co Parks & Recreation Dept & FSK Antique Car Club, Inc. is neither responsible nor liable for any vehicle damage, theft or personal injury.
All info is subject to change (Revised 10/8/18)

ODD BUT TRUE CORVAIR STORY

A lady wanted to be buried in her EM vair sitting behind the wheel! She made all her own funeral arrangements and while she was not allowed to be seated in the car she did get her wish and was buried in it. EPA or what ever required that engine trans be removed along with the fuel tank and all fluids like brake etc. She had to buy 4 grave plots to accommodate the size of the car a special sized vault was made to hold it and the rear window and panel below it along with the seats were removed the casket was tilted slightly and slid through the rear opening into the car picture in the paper shows the vair hanging from a crane with the casket inside being lowered into her grave.

Corvair Cooks Corner

PDF by Professor Eric Corvair



(taken from of Home

Summer Chicken Macaroni Salad

of Internet)

Ingredients

- 1-1/2 cups uncooked elbow macaroni
- 1 rotisserie chicken, skin removed, shredded
- 3/4 cup fresh or frozen peas
- 5 green onions, finely chopped Macaroni
- 2 celery ribs, thinly sliced
- 1/3 cup loosely packed basil leaves, thinly sliced
- 1/4 cup lemon juice, divided
- 1 teaspoon kosher salt
- 3/4 teaspoon coarsely ground pepper
- 3/4 cup (6 ounces) plain yogurt
- 3/4 cup reduced-fat mayonnaise
- 3 medium peaches, peeled and sliced
- 1 cup (4 ounces) sharp cheddar cheese, shredded
- 1/2 cup crumbled Gorgonzola cheese
- 3/4 cup pistachios



Directions

- Cook macaroni according to package directions. Meanwhile, mix chicken, peas, onions, celery, basil, 2 tablespoons lemon juice, salt and pepper. Drain macaroni; rinse with cold water, then drain again. Add to chicken mixture.
- Mix yogurt, mayonnaise and remaining lemon juice. Add to salad and mix well. Add peaches and cheeses; toss gently. Refrigerate at least 2 hours. Sprinkle with pistachios before serving.

Nutrition Facts: 3/4 cup: 312 calories, 16g fat (5g saturated fat), 85mg cholesterol, 379mg sodium, 13g carbohydrate (5g sugars, 2g fiber), 29g protein.



PDF Compressor Free Version

A Fun Fact...

How unique is the name Corvair?

From 1880 to 2017 less than five people per year have been born with the first name Corvair. *Hoorah! You are a unique individual.*

Secretary's Report of April 2019

Submitted by
Earl Holmes



The meeting was called to order by our president, JOHN Berkheimer, at the Hoss's Restaurant in York.

The secretary read the minutes from the March meeting which included the request for nominations for club officers, the scheduling of club activities for the upcoming year, and the tech session by Dave Steigauf on the installation of electric fuel pumps into a Corvair. John Berkheimer gave the Treasure Report.

New Business

- ◆ JOHN Berkheimer requested to know who was planning on attending the club activity in April at John Warren's home. If you plan on attending this activity, please call or e-mail John Warren so that he will have an idea of how many members are planning to attend.
- ◆ JOHN Berkheimer stated that he contacted Penn Collage to plan a club activity, however, he hasn't heard back from them.

Announcements

- ◆ Ron Hash was the winner of the 50/50 drawing this month. Congratulations Ron.

A motion was made by Dave Steugauf to adjourn the meeting and seconded by John Johnson and the meeting was adjourned.

The next meeting is scheduled to be held May 14th at the Hoss's Restaurant in York.

Attendees

John and Sandy Johnson	Ron and Betty Hash	Rich and Cindy Heisler
Dave and Sally Fullerton	JOHN Berkheimer	Bruce Culp
Dave Steigauf	Linda Enfield	Tom Zinn
Jeff Ostroff	Brian Kopp	Steve Sabaka



Newsletter Articles are due by the 20th of each month.



Thank you so much for all the cards of encouragement and especially all the prayers during my illness. I still have a long way to recovery, but hanging in there and taking each day by day.

Hope to see you all soon.

Carol



Your expertise is wanted!

Submitted by Carol Trimper

I'm looking for anyone and everyone who could share their experiences and knowledge about their corvairs. I would like to have a tech sessions (like Dave Steigauf's article in last months newsletter) or stories about your corvair. We need more corvair articles for our newsletter. You never know when your words, comments, or suggestions could help another corvair owner. Your help is wanted for newsletter articles.

CENTRAL PENNSYLVANIA CORVAIR CLUB, INC. (C.P.C.C.)

C.P.C.C. is a chapter of "CORSA" (Corvaire Society of America). CORSA is a rapidly growing international organization now is boosting over 4000 members and 120 local chapters worldwide.

PDF Compressor Free Version

The C.P.C.C. Chapter has monthly social/family meetings at various locations within the region. Each month you will receive a newsletter announcing the meeting location. The newsletter also contains information about our club members, technical tips, other club activities, auto events, and classified ads.

- The club is for the preservation and interest of the Corvaire automobile.
- We sponsor Corvaire shows, rallies, mini conventions, caravans, parties, and dinners. All of our events are for the member's immediate family.

Dues are payable to: Central Pennsylvania Corvaire Club (C.P.C.C.)
c/o John Berkheimer
403 Dart Drive
Hanover, PA 17331

_____ New Membership is \$ 16.00 per year OR \$ 30.00 for two years.
_____ Renewal of membership is \$ 16.00 OR \$ 30.00 for two years.
_____ Interested in joining CORSA.

Member Name: _____ Spouse Name: _____
First Middle Last First Middle Last

Address: _____

City: _____ State: _____ Zip Code: _____

Home Phone: _____ Cell Phone: _____ E-Mail: _____

Number of Corvaire owned (if any)

Year: _____ Model: _____ Body Style: _____ Serial Number: _____

Year: _____ Model: _____ Body Style: _____ Serial Number: _____

Member's Birthdate: _____ Spouse's Birthdate: _____
Month Day Month Day

Wedding Anniversary Date: _____
Month Day Year

Child's Name: _____ Birth Date: _____

Child's Name: _____ Birth Date: _____

Recommended By: _____

Any applicant whom is under the age of (18) eighteen, a parent or legal guardian must sign the application.

Applicant: _____ Date: _____
Signature

Parent or Guardian: _____ Date: _____
Signature

Parent or Guardian: _____
Print full name

The Central Pennsylvania Corvair Club (C.P.C.C.) is a non-profit organization dedicated to the preservation of the Corvair and Corvair powered vehicles. We provide knowledge about the Corvair to our members and other car enthusiasts, as well as hold monthly meetings, events, and social gatherings for the enjoyment of our members.

PDF Compressor Free Version

C.P.C.C. is Chapter #170 of the Corvair Society of America (CORSA). Dues for C.P.C.C. are \$16.00 per year or two years for \$30.00, which must be sent in the form of a check or money order payable to "C.P.C.C." and mailed to C.P.C.C. Treasurer, c/o John Berkheimer, 403 Dart Drive, Hanover, PA 17331. It is suggested that C.P.C.C. members also become members of CORSA, the national organization. CORSA dues are \$45.00 per year. Dues may be sent to CORSA, P.O. Box 607, Lemont, IL 60439-0607 or online at <http://members.corvair.org>.

Newsletter submissions should be sent to the Newsletter Editor, Carol Trimper at lcl@pa.net. Mailing address is 30 Wheaton Drive, Littlestown, PA 17340.

All other club inquiries should be directed to the C.P.C.C. Secretary, Earl Holmes, 1511 Hicks Drive, Dauphin, PA 17018.



Visit us on our website: centralpacorvairclub.org



The Four Wheel Independent
30 Wheaton Drive
Littlestown, PA 17340