



# *the fifth wheel*

JUNE 2026

[HTTP://WWW.CORVAIR.ORG/CHAPTERS/LVCC](http://www.corvair.org/chapters/lvcc)

1976 - 2026 .... IT'S OUR 50th ANNIVERSARY!

## ***Inside this issue***

<i>Radioactive Spark Plugs!</i> <i>from Bob King</i>	2
<i>LVCC Treasury Report</i> <i>by Joan Lacki</i>	2
<i>LVCC Meeting Minutes</i> <i>by Greg Dittrich</i>	2
<i>Goofy Stuff for Your Corvair</i> <i>from KaleCo Auto</i>	3
<i>Noises from the Rear</i> <i>by Mike Dawson</i>	4
<i>Das Awkscht Fescht</i> <i>Registration Reminder</i>	6
<i>LVCC Classified Ads</i> <i>Buy &amp; Sell</i>	7
<i>Calendar of Local Events</i> <i>for Car People</i>	8
<i>AOW Museum Map</i> <i>Our Meeting Location</i>	10
<i>Contact Info for LVCC</i> <i>Officers and Volunteers</i>	10



*The Fifth Wheel* is published monthly by Lehigh Valley Corvair Club Inc. (LVCC), a chapter of the Corvair Society of America. We accept articles of interest to Corvair owners for publication. Classified advertising of interest to Corvair owners is available free of charge to all persons. Commercial advertising is also available on a fee basis. For details, email our newsletter editor, Allan Lacki, [redbat01@verizon.net](mailto:redbat01@verizon.net).



# Radioactive Spark Plugs! Submitted by Bob King

I was watching a science program about the periodic table of elements. It featured a highly radioactive element named polonium. It was discovered by Marie and Pierre Curie early in the 20th century. It has few uses. One exception is that it can be used as a trigger to detonate an atomic bomb! And then, some genius decided, you can coat a spark plug with it to improve combustion, horsepower and acceleration!

Since the 1/2 life of polonium is only 4 months, by the time you installed the plugs, the output was already 1/2 (lucky for your mechanic!). The level of radiation was actually low and alpha particles will not penetrate skin, but if you ingest it... You're *DOOMED!*

Get yours on Ebay of course (but they were only made for 40's & 50's cars.). Enjoy! Bob King

## Additional Notes:

The Radiation and Radioactivity Museum (there actually is such a place – Ed.) indicates that official advertising for the polonium spark plugs ran from 1940 to 1953. The only “media” support they received came through the “November 1941” issue of Science Digest, reporting that the vehicle needed “30 percent fewer revolutions” to start the engine.

In practice, the most likely explanation is that any perceived benefit was tied to the simple act of replacing the spark plugs themselves (clean and new, without deposit buildup). As if that weren't enough, polonium's effects were doomed from the start: With a half-life of 138.3 days for isotope 210 (the most abundant out of a total of 42), polonium turns into lead-206.



## LVCC Treasury Report By Joan Lacki

<b>Beginning Balance: (April 30, 2026)</b> .....			<b>\$2,304.38</b>
Receipts:			
Membership		\$0.00	
Other		\$0.00	
			<b>\$0.00</b>
Expenses:			
Newsletter Exp (Allan Lacki)		-\$27.79	
			<b>-\$27.79</b>
<b>Ending Balance: (May 31, 2026)</b> .....			<b>\$2,276.59</b>

## LVCC Meeting Minutes by Greg Dittrich

Our latest meeting was held on Saturday May 16 at the America on Wheels Museum. It was called to order at 10:24 AM. We had 11 members in attendance. Prior to the meeting, our group enjoyed conversations outside and viewing each other's cars.

There were no minutes from the April meeting as we were conducting our swap meet instead that month.

The Treasurers Report – April 's ending balance was \$2,304.38 and, after a motion by Scott Oberholzer and seconded by Bob Marlow, the report was approved.

Membership stands at 57.

### Old Business

LVCC's All-Corvair Swap Meet was held on Saturday April 18, 2026. A number of members attended. As always, a fun, successful event! There was a net loss of \$-67.06 for conducting the event. The goal for this event is to provide a fellowship opportunity for the Corvair community and isn't intended as a fundraiser. Excess food was donated to the Help-

*(Continued on page 4)*

# For Your Corvair! *Source: <https://shorturl.at/fxnaE>*



ing Harvest food pantry in Reading, PA.

### New Business

President Al Lacki shared that he filed our Corporate Annual Report to the Pennsylvania Secretary of State's office as required.

### LVCC Activities

LVCC's 50<sup>th</sup> anniversary was discussed. It was proposed that we have a gathering/show at the AOW museum. Scott Oberholzer suggested we consider inviting a food truck(s). The site would provide an indoor backup should we have bad weather. Al Lacki said he will reach out to Monica Ziobro, Manager of the museum to discuss if this would be possible.

Edwin, Ryan and Wes are creating a design for T-shirts and perhaps pins to commemorate our anniversary.

It was suggested that we reach out to the Wheels of Time Street Rod Association of Lehigh County as they have a car "Teeter Toter" that challenges drivers to balance their cars in the least amount of time. It would provide an interesting and fun activity.

We are also planning to display our Corvairs at the Das Awkscht Fescht car show being held on Sunday, August 2<sup>nd</sup>. We always have strong attendance and this would provide a perfect alternative for the club's 50th anniversary celebration.

NECC News - President Al shared that the next track day will be on Monday, June 22<sup>nd</sup> at Summit Point Motorsports Park – a facility that has several circuits. NECC is renting the Shenandoah Circuit which features 22 turns and a banked turn that replicates the famous "Karussell" at Nurburgring, Germany. Registration is open. There are a number of Stingers expected to attend a planned reunion. The date will allow attendees to still attend the CORSA Convention.

The annual convention of the Corvair Society of America will be held on June 22-26<sup>th</sup> in Gettysburg, PA.

Next meeting: Saturday June 20th.

### Other Discussion

Scott Oberholzer mentioned that he was watching American pickers and the show featured a gentleman who had built a variety of cut-a-way engines. Among his collection was a Corvair engine!

Pete Pesaresi shared that while preparing his car for the convention, he discovered that his brake shoes were cracked. He's replacing them and questioned if he should have the

drums honed. After some discussion, the consensus was to buy new drums as they cost between \$40-\$60.

### Adjournment

On a motion by Edwin Buitter and seconded by Bill "Senior" Dittrich, the meeting was adjourned at 11.37 AM.

Respectfully submitted by Greg Dittrich.

---

## Noises from the Rear

### by Mike Dawson

*Source: May 2026 issue of "The Flat Six", the official newsletter of the Prairie Capital Corvair Association.*

This month, we'll attempt to help diagnose noises from the rear of the car. Drive train noises also apply to FC vehicles.

- A rolling noise that does not change in pitch from acceleration to deceleration in the same speed range is usually a wheel bearing. Wheel bearings on early models usually squeak or make a cycling growl. Late bearings will squeak, make a raspy noise or howl.
- A clank when starting from a stop or going into gear may be a U-joint. They can also make a clinking noise, usually at low speed. Loose axle yokes on early models and FC can make the same noise.

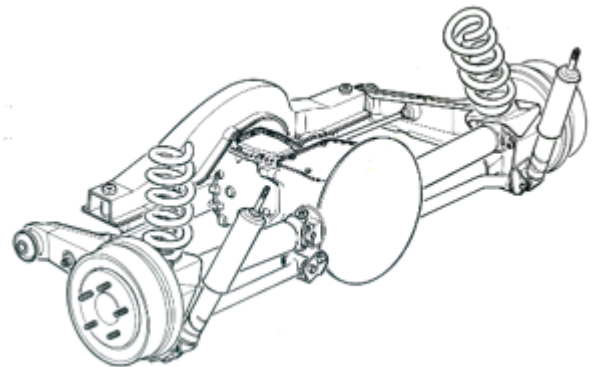

- Howling that changes noticeably between acceleration and deceleration is either a worn-out pinion gear, mismatched ring and pinion gear or very loose or worn-out pinion bearings.
- Thunking noises on late models can be either the top or bottom shock mount. Check for shifted lower bushings or rusted top mounting pads. The latter can be repaired.

- Squeaking from one side of a late model going over bumps can be a trailing arm bushing that has popped out of its shell. The arm is rubbing on the bracket and the tire is way out of toe alignment.
- A heavy thump or clunk going over a quick rise may be a separated motor mount on a 1965 model. The other models make less noticeable noises unless almost terminal. Best to check them every time you change oil filters if they are original.
- A loud squawk that occurs briefly as you push in or release the clutch is a pilot bushing problem. Always replace it any time the transaxle is separated as they take a set very quickly.
- A knocking noise at idle which disappears or gets quieter when depressing the clutch is a flywheel with loose rivets (all years, all models of manual transmissions).



*Stick-shift Corvairs have an unusual 2-piece flywheel that was hot-riveted from the factory.*

- A squeal or light rattling noise that is only noticed when holding down on the clutch pedal is a clutch release bearing.
- A moaning sound that is heard only when the engine is cold is probably a late model blower bearing that needs greasing or replacing. Early model bearings usually start a continuous metallic rumbling noise due to their design.
- A light to heavy tapping noise that goes away after driving is usually a lifter that has lost its oil temporarily. Long storage or cold startups and quick shutdowns cause lifters to go "flat". Frequent oil changes and avoiding a lot of start-ups without driving helps this problem. Age and sometimes dirt interfere with lifter check valve action.
- A lighter tapping noise that sounds like a lifter may be a bad exhaust valve guide. The exhaust gas blowing down the guide sounds almost metallic.
- A persistent squeak (usually Powerglide cars) that only occurs at a stop, in gear with your foot on the brake may be the rear parking brake cable at its support brackets or on the backing plate on the inside of the brake drum. To test this theory, pull slightly on the parking brake handle when the squeak occurs. If it stops, you have found the problem. The idling engine gently tugs on the spring attached to the cable assembly: install the missing clips on the two support brackets, grease them and use brake lube under the cable inside the brake drum.
- A chirping from the engine that is noticeable only on acceleration may be a loose cylinder head. Retorque the heads immediately or you will have blown head gaskets. This is usually caused by overheating and can sometimes result in studs pulled out of the crankcase. You can also get a bad smell in the heater since combustion gas is escaping.
- An actual blown (burned through) head gasket will make a persistent spit-spit-spit noise as the engine idles. The noise will get louder under a load and bad fumes get in the heater.
- A mild howling from four speed transmissions up through 1965 that is only heard in first, second and third is probably the needle bearings and shaft in the counter gear. The noise is gone in fourth gear since the counter gear is not loaded. A common problem and replacement parts are available.
- A clicking noise from the rear of early models & FC at very slow speed may be the brake shoes snapping across backing plate pads as they try to follow an out of round drum or a slightly bent axle (common problem). Apply brake lube to the pads or correct the problem. This can also be a bad U-joint or a badly worn stub axle that is rocking the side gear of the differential.



## Das Awkscht Fescht Corvair Row! Sunday August 2, 2026 is Club Day

Club Day at the Fescht is a favorite for Corvair lovers across the region because we have a full row reserved on the show field just for us, courtesy of LVCC member extraordinaire Randy Kohler!

We typically draw 40 Corvairs of all years and models. It's a great way to get together with folks from all the regional Corvair clubs.

Show Car Registration Fee: Registration through December 31, 2025: \$17.00 per day per vehicle. Registration January 1 through July 1, 2026: \$20.00 per vehicle. Spectator Admission: \$10 per adult, FREE for age 15 and under.

Online registration is available, but the registrar adds \$3.18 to the fee. Avoid the fee by registering by US Postal. To do it, download the registration form at <https://awkscht.com/>

Or if you don't mind sacrificing a copy of this newsletter, print it and cut out the form shown below. We are Club #6.



NECC Motorsports a.k.a. Northeast Corvair Council, Inc.

### CORVAIR TIME TRIALS!

SUMMIT POINT MOTORSPORTS PARK  
Monday, June 22, 2026  
[www.neccmotorsports.com](http://www.neccmotorsports.com)

### SUNDAY

**AUGUST 2, 2026**

**Registration Form Only - No Day of Show Registration**  
**Post Mark Deadline: July 1, 2026**  
**NEED NOT BE A CLUB MEMBER**

#### USE GATE #1 ONLY

NEW ADDRESS:  YES  NO  
(TYPE OR BLOCK PRINT, PLEASE)

NAME \_\_\_\_\_ YEAR \_\_\_\_\_ MAKE \_\_\_\_\_  
STREET \_\_\_\_\_ MODEL \_\_\_\_\_  
TOWN \_\_\_\_\_ BODY STYLE \_\_\_\_\_  
STATE \_\_\_\_\_ ZIP \_\_\_\_\_ +4 \_\_\_\_\_

PHONE/AREA CODE ( \_\_\_\_\_ ) \_\_\_\_\_  
Make checks or money order only, payable to: Das Awkscht Fescht  
Mail to: Box 127, Macungie, PA 18062-0127  
PLEASE DUPLICATE THIS FORM FOR ADDITIONAL VEHICLES.  
Registrant consents to the use of images of registrant and vehicle  
in later publications by Das Awkscht Fescht organizers.

CLUB NUMBER (FROM LIST BELOW) \_\_\_\_\_  
Sunday  
Registration through December 31, 2025: \$17.00 per vehicle  
Registration January 1 through July 1, 2026: \$20.00 per vehicle  
ONLY ONE TENT PER CLUB ALLOWED No Refunds  
LIMIT FOUR (4) PERSONS PER VEHICLE

OFFICIAL USE ONLY	
F.S.	<input type="text"/>
S.	<input type="text"/>
S.S.	<input type="text"/>

**WHICH CLUB ARE YOU ENTERING - BY NUMBER**  
CHECK PAGE 4 FOR INFORMATION

- |                        |                                   |   |                       |
|------------------------|-----------------------------------|---|-----------------------|
| 1 - Chrysler Products  | 11 - Model A Ford                 | 22 - Checker                                    | 32 - Crosley          |
| 2 - Chevrolet          | 12 - Thunderbird                  | 23 - Nat. Woodie Club                           | 33 - Mercedes Benz    |
| 3 - Pontiac            | 13 - Willys                       | 24 - Ford Falcon, Fairlane                      | 34 - Oldsmobile       |
| 4 - Corvette           | 14 - Nash & Rambler               | 25 - Kaiser, Frazer, Henry J., AllState, Darrin | 35 - VCCA             |
| 5 - Studebaker, Avanti | 15 - Chev. Nomads, Pontiac Safari | 26 - Packard                                    | 36 - VW               |
| 6 - Corvair            | 16 - Auburn, Cord, Duesenberg     | 27 - Mustang                                    | 37 - Mopar Madness    |
| 7 - Metropolitan       | 17 - Shelby Mustang               | 28 - Rolls-Royce & Bentley                      | 38 - British Car Club |
| 8 - Buick              | 18 - Franklin                     | 29 - Foreign Cars                               | 39 - Happy Motoring   |
| 9 - Cadillac & LaSalle | 19 - Hudson                       | 30 - All 1927 & Earlier Cars                    | 40 - Truck Club       |
| 10 - Early Ford V-8    | 20 - Dodge & Graham               | 31 - Oakland                                    | 41 - Jeep Club        |
| 10A - Ford             | 21 - Edsel, Mercury, Lincoln      |   | 42 - Street Rods      |

**REGISTRATION BY ONTELAUNEE CAR CLUB, PARKING BY THE INDIVIDUAL CLUBS.**  
FOR CONFIRMATION, PLEASE SUPPLY SELF-ADDRESSED, STAMPED ENVELOPE WITH REGISTRATION

**For Sale:** 1969 Monza Convertible, 140 hp, 4-speed, #3812, 27,200 original miles. Rare and one of the best remaining! No rust and never under-coated. Butternut Yellow, Black interior & power top, Posi, Rear antenna, Clock, Aux lighting, Bumper guards, Tinted windows, wire caps. Numbers matching. Excellent original and correct example, good running/driving southern car. \$29,500, Lots of pictures available. Dave Leonard, 69corvairs@gmail.com, 908-612-7499



**For Sale:** Sun Star 1/18 scale model of a 1963 Corvair Monza. This vintage, like new model, is white with red interior. It's still in its original packaging. Asking \$50. Any interested party can call or text me, Paul Pagoda, at (610) 883-1469. Email: ppagoda1948@gmail.com

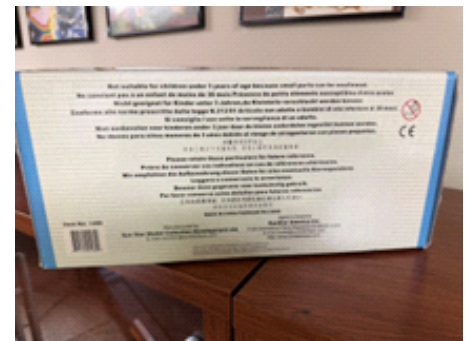

**For Sale:** 1965 Corvair Monza Convertible. 110 / Powerglide. Evening Orchid with white interior. 61,000 miles. Meticulously maintained by LVCC Member Fred Scherzer. Asking \$18,000. Contact: Jeff Scherzer (Fred's son). (484) 948-5140 or jscherzer02@gmail.com



**For Sale:** Contact Larry Asheuer if interested in any of the following offers. [a-lcorvair@msn.com](mailto:a-lcorvair@msn.com)

- **1965 Corvair Drag Race Car** (Set up for NHRA Bracket Racing 2018) - \$4,000. This Corvair is totally set-up for Drag Racing and is NOT street legal (15.29 Sec @ 90 MPH).
- **For Sale: 1966 Corvair Monza Convertible.** Project Car - \$2,500. Car was taken completely apart by previous owner. Larry is slowly making it a roller. This Corvair has a very solid Body. It is a Project Car.
- **For Sale: New Parts:** Brakes hoses, air filters, oil filters, tune-up parts, brake shoes, shocks, tail light lenses, gaskets, plugs, cables, choke pull offs, and much much more. Used Parts: Too many to list. Contact Larry Asheuer for pricing. Phone (267) 994-1569 or email: [a-lcorvair@msn.com](mailto:a-lcorvair@msn.com)

**Sky King Automotive Services:** Now offering Corvair head work. Valve-seat grinding, Pro Flow grinding/ polishing, cleaning-cutting head gasket surfaces, de-flashing , thread repair. (I have measurement equip to confirm correct gasket surface depths). HV carb rebuilding. Top engine cover modifications for one gasket, no more leaks! Sound proofing, gas tank replacements, as well as rear and front axle bearing units. Late rears in stock! Bob King [kcorvair@ptd.net](mailto:kcorvair@ptd.net) or text/call to 610-442-2873.

# LVCC Calendar of Events



## Cruise Nights

Interested in doing a cruise night? Go to <https://carmacruisefinder.com/> It's easy to use and lists more cruise events than we could possibly fit in this newsletter!

## Corvair Events, Car Shows, Etc:

### Sunday June 7, 2026. 47th Annual General Motors on Display Show.

Location: Macungie Memorial Park, Rt 100, Macungie, PA. Time: 9 AM to 3 PM. Rain or shine. Day of Show Price: \$20 per show car. The show is open to any vehicle that has been or is made by GM. No judging. Flea market. DJ. Food: Coffee, donuts, hot breakfast. Hot & cold lunch items will be served after 11 AM. For more information, contact Tom Wright. Phone (610) 587-3468. Email: [tommyjw22@yahoo.com](mailto:tommyjw22@yahoo.com). Pre-Register online at [www.kscpoci.org](http://www.kscpoci.org) and save \$5!

### Sunday June 7, 2026. Red Coffin Memorial Car Show.

Location: Lyons Fire Company Exhibition Grounds, 110 Park Avenue, Lyons, PA 19536. Time: 8 AM to 3 PM. Day of Show Price: \$20 per show car. (All race cars are free!). Antiques, classics, customs, street rods, rat rods, race cars. Participant judging. Music, silent auction, 50/50 drawing, raffle prizes. Dash plaques and goodie bags to the first 100 registered. Host: Reading Fairgrounds Racing Historical Society. Contact: Darrell Merman (484) 516-7457. [www.readingfairgroundsracing.com](http://www.readingfairgroundsracing.com).

### Friday June 12 - Sunday June 14. 50th Annual Corvair Recall.

Location: Hampton Inn Syracuse Clay at 3948 State Route 31 Liverpool, New York 1309. All air-cooled vehicles welcome. Ice cream social road tour, car show (judged), valve cover racing, fanbelt toss, prizes, raffles, social hour, dinner, awards, farewell breakfast. Website & Registration: <https://www.cnycorvair.com/Recall2026.php> Hotel Reservations: (215) 622-3443. Press "O" for local desk. Mention "CNY Corvair Club" for discounted rate. Hotel is pet-friendly. Room rate is good until May 13, 2026. Need more info? Contact Neil Reitmeyer (570) 351-8168 or Corina Edwards (315) 419-3638.

### Saturday June 13, 2026. Gasket Goons Spring Showdown.

Location: Macungie Memorial Park, 50 Poplar Street, Macungie, PA 18062. Gates open 8 AM. Band starts 9:30 AM. Valve cover racing starts at Noon. Trophies at 3 PM. Limited to 1969 and prior cars & trucks! Show car price: \$20. Spectator price: \$10. Facebook/[gasketgoonspa](https://www.facebook.com/gasketgoonspa).

### Saturday June 13, 2026. Pre-Father's Day Show.

Location: Classic Auto Mall, 6180 Morgantown Road, Morgantown, PA 19543. Rain date: June 20. Time: 10 AM to 3 PM. Price: \$20 plus 2 non-perishable food items for the food bank per show car. All classes welcome: Street rods, muscle cars, classics, Vettes, antiques, trucks. Live music, door prizes, goodie bags. 100 trophies by People's Choice. Contact: Pastor Lawrence Weed (610) 322-1622. [pastorweed@hotmail.com](mailto:pastorweed@hotmail.com). [Chariots-of-fire.org](http://Chariots-of-fire.org).

### Saturday June 20, 2026. 20<sup>th</sup> Annual Fleetwood Rotary Show of Wheels

Location: Fleetwood Community Park, 334 West Main Street, Fleetwood, PA. Time: 8 AM to 3 PM. Judging at noon. Day of show price: \$20 per show vehicle. (\$15 if you pre-register by June 13). Trophies and prizes for standout vehicles in multiple categories. Goody boxes and dash plaques to the first 250 registered participants. Door Prizes, 50/50 Drawing, Rubber Duck Race, Chance Auction, Live Music. Contact John Leibelsperger at (610) 781-8949.

### Sunday June 21, 2026. 24<sup>th</sup> Annual Father's Day Car Show at Silver Creek

Location: 2943 Route 212, Springtown, PA 18081. Time: 9 AM to 3 PM. (Rain or Shine). Pre-registration is \$10 per car. \$15 on the day of the show. Flea market, food & beverages, music. This is a big show, with over 1,500 cars expected. (610) 346-6840 [scaacarshow@gmail.com](mailto:scaacarshow@gmail.com)

### Sunday June 21, 2026. 16<sup>th</sup> Annual Father's Day Car Show

Location: Womelsdorf Town Park. (Entrance on Water St.). Time: 10 AM to 3 PM. Rain Or Shine. Day-of-Show Price: \$15 per car. Live music, Food & beverages at affordable prices. Entertainment & food provided by: Community Assoc & Women of Today. Participants choice awards for the nicest cars. For More Information: Ray E. Swope, Jr. (610)-589-5616 and Paul Hopple (610) 589-5349.

*(Continued from page 8)*

Monday June 22 - Friday June 26, 2026. Corvair Society International Convention.

Location: Historic Gettysburg, PA. The four host chapters—Mid Maryland Corvair Club, Group Corvair, Northern Virginia Corvairs and Central Pennsylvania Corvair club- are working to put together a great time in this beautiful and historic area. The Convention will include a welcome party, concour d'elegance, road rally, autocross, economy run, tech sessions, banquet & awards ceremony and more. Registration & hotel reservations opening early 2026. Join now to be part of the action! Participation limited to CORSA members. More information at [www.corvair.org](http://www.corvair.org).

Sunday, July 26, 2026 - Road Angels Car Show.

Location: Dublin Volunteer Fire Company, 194 N. Main Street, Dublin, PA 18917. Time: 9AM to 3:30 PM. Day of show price: \$20 per show vehicle. Trophies for: best of show-stock, best of show-modified, club participation, long distance award, president's choice, ladies choice, favorite 30 selections, favorite interior, favorite motor, favorite paint, rat rod, under 30 participants also, door prizes, pre-registered prizes, 50's DJ, flea market spaces, coffee & donuts for early birds. Vehicles must meet the 30 year old window and must be on the show grounds to qualify for prizes and awards. If you have any questions, please send an email to: [altursi@gmail.com](mailto:altursi@gmail.com)

Sunday August 2, 2026 – Corvair Row at the Das Awkscht Fescht Car Show

Location: Macungie Memorial Park, 50 Poplar Street, Macungie, PA. Time: 7:30 AM to 4 PM. Sunday is Car Club Day at Das Awkscht Fescht and Randy Kohler has reserved a full row on the show field just for us! Of course, anybody with a Corvair can park in Corvair Row. It's a great way to get together with folks from all the regional Corvair clubs to get together. Show Car Registration Fee: Registration through December 31, 2025: \$17.00 per day per vehicle. Registration January 1 through July 1, 2026: \$20.00 per vehicle. Spectator Admission: \$10 per adult, FREE for age 15 and under. Online registration is available, but the registrar adds \$3.18 to the fee. Avoid the fee by registering by US Postal. To do it, download the registration form at <https://awkscht.com/>

Saturday August 8, 2026. RFRHS Classic Car & Race Car Show.

Location: North parking lot at the Classic Auto Mall, 6180 Morgantown Road, Morgantown, PA 19543. Time: 8 AM to 2 PM. Day of Show Price: \$20 per show car. (All race cars are free!). Antiques, classics, customs, street rods, rat rods, race cars. Participant judging. Music, silent auction, 50/50 drawing, raffle prizes. Dash plaques and goodie bags to the first 100 registered. Host: Reading Fairgrounds Racing Historical Society. Contact: Darrell Herman (484) 516-7457. [www.readingfairgroundsracing.com](http://www.readingfairgroundsracing.com).

Saturday August 22, 2026. First State Corvair Club Annual Show.

Location: Limestone Presbyterian Church, 3201 Limestone Road, Wilmington, DE. Time: 9 AM to 2 PM. Price: \$20 per car. Hosted by First State Corvair Club. Corvairs, music, food, family fun.

Saturday August 31, 2026. Boyertown Community Park – Duryea Day

Location: 419 S Madison St, Boyertown, PA 19512. Time: 9 AM to 3 PM. Price per show car: Not listed. Spectator admission is \$10 for adults, free for ages 12 & under. Admission includes both the Park and the Boyertown Antique Auto Museum. Pre-registration and day-of-show registration for show vehicles available. All makes, models, and years are welcome. Contact [michaela@boyertownmuseum.org](mailto:michaela@boyertownmuseum.org) <https://boyertownmuseum.org/duryea-day/>

Saturday September 12. Fall Fest Car Show.

Location: Classic Auto Mall, 6180 Morgantown Road, Morgantown, PA 19543. Rain date: September 19. Time: 10 AM to 3 PM. Price: \$20 plus 2 non-perishable food items for the food bank per show car. All classes welcome: Street rods, muscle cars, classics, Vettes, antiques, trucks. Live music, door prizes, goodie bags. 100 trophies by People's Choice. Contact: Pastor Lawrence Weed (610) 322-1622. [pastorweed@hotmail.com](mailto:pastorweed@hotmail.com). [Chariots-of-fire.org](http://Chariots-of-fire.org).

Saturday, September 19, 2026.- CPCC Corvair Day

Location: Eastern Museum of Motor Racing, 100 Baltimore Road, York Springs, PA 17372. 9 AM to 4 PM. A Corvair show with 50/50, free dash plaques, door prizes, and silent auction. Free indoor/outdoor vendor setup. On-site food vendor will offer breakfast, lunch, snacks, and beverages to purchase. Registration 9AM - 12PM. Hosted by the Central Pennsylvania Corvair Club Contact: Dave Steigauf, (H) (717) 898-7927 or (Cell) (717) 406-7382. [davescorsa@gmail.com](mailto:davescorsa@gmail.com).

SAVE THIS DATE! Sunday September 13, 2026. LVCC 50th Anniversary Celebration!

The Lehigh Valley Corvair Club had its first meeting on September 15, 1976 at 327 Montgomery St Allentown, PA. That's fifty years ago, so it's time for a celebration! Tentative location: America On Wheels Museum, 5 North Front Street, Allentown, PA 18102. More information to follow!

## ***Next LVCC Meeting. We Meet Here!***

Next Meeting Date: ***Saturday June 20, 2026***

Time: 10 AM to Noon

Place: America On Wheels Museum, 5 North Front Street, Allentown, PA 18102

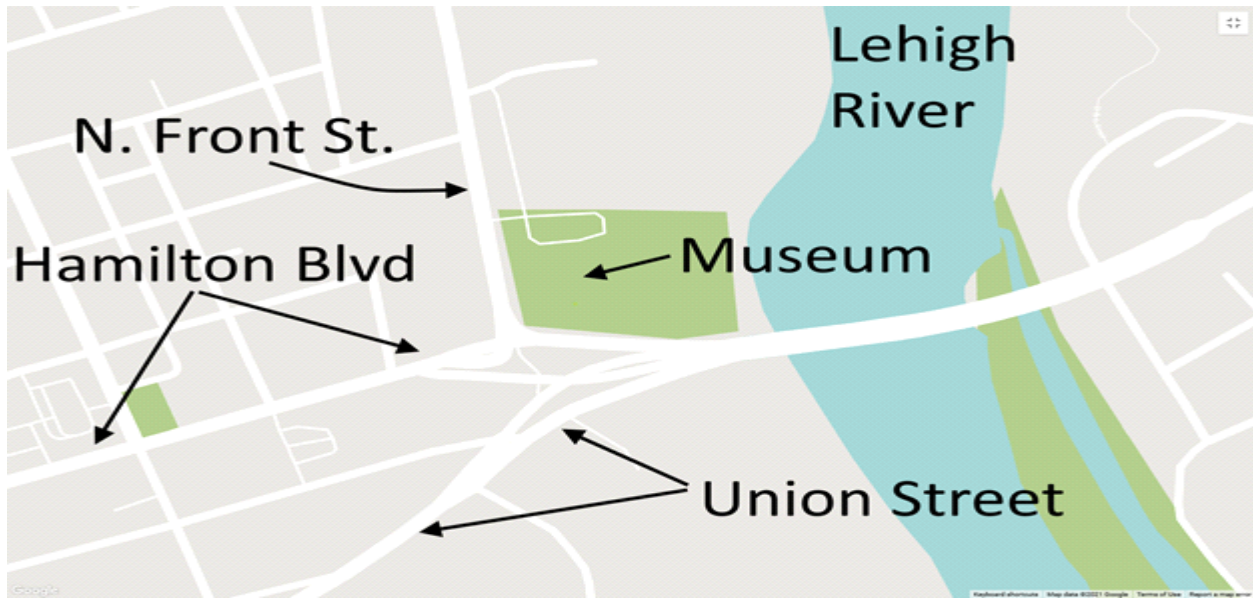

**Clark's**  
Corvair Parts®

**Clark's Corvair Parts®**  
400 Mohawk Trail  
Shelburne Falls, MA 01370  
(413) 625-9776  
www.corvair.com

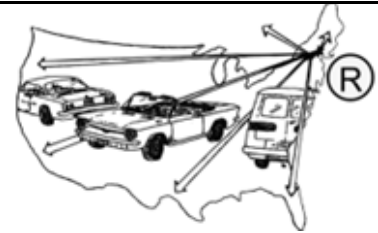

2019-2025 CATALOG Now Available. Order a copy or view online at [www.corvair.com](http://www.corvair.com). Clark's provides door prize gifts at no cost to LVCC for Das Awkscht Feschct.

## ***LVCC Officers & Volunteers***

President & Newsletter Editor: Allan Lacki Phone: (610) 927-1583 Email: [redbat01@verizon.net](mailto:redbat01@verizon.net)

Vice Pres: John Egerton Phone: (610) 217-0514 Email: [jegerton@ptd.net](mailto:jegerton@ptd.net)

Secretary: Greg Dittrich Email: [gdittrich1@gmail.com](mailto:gdittrich1@gmail.com)

Treasurer: Joan Lacki Phone: (610) 927-1583 Email: [joantlacki@verizon.net](mailto:joantlacki@verizon.net)



LVCC's Instagram Account, [lehigh\\_valley\\_corvair\\_club](https://www.instagram.com/lehigh_valley_corvair_club), is maintained for us by Ryan Cengeri, [halfmile@gmail.com](mailto:halfmile@gmail.com)  
Contact Ryan to have your favorite Corvair photos posted on Instagram!