

FRONT SEAT SHOULDER STRAP INSTALLATION INSTRUCTIONS

ALL CONVERTIBLE STYLES

QUARTER ANCHORAGE

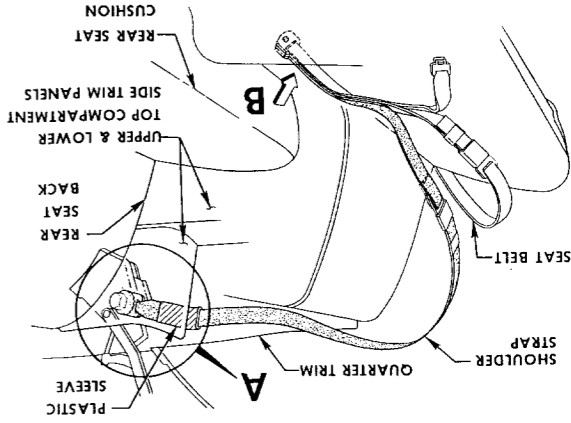

- TO INSTALL FRONT SEAT SHOULDER STRAP TO CONVERTIBLE QUARTER ANCHOR, REMOVE REAR SEAT BACK AND SEAT CUSHION. REMOVE UPPER AND LOWER TOP COMPARTMENT SIDE TRIM PANELS.
- EXAMINE VIEW A CAREFULLY. LOCATE SPECIFIC BOLT USED IN YOUR CAR OR LOCATION OF NEW BOLT, IF APPLICABLE.
- REMOVE EXISTING HINGE ANCHOR BOLT WHEN NECESSARY.
- SECURE SHOULDER STRAP TO HINGE SUPPORT AS SHOWN WITH EXISTING OR NEW ANCHOR BOLT.
- INSTALL UPPER AND LOWER TOP COMPARTMENT SIDE TRIM PANELS. MARKING SURE THAT THE PROTECTIVE SLEEVE IS POSITIONED BETWEEN SIDE TRIM PANELS AND QUARTER TRIM.

CHEVROLET IMPALA
PONTIAC CATALINA, GRAND PRIX
& BONNEVILLE
OLDSMOBILE EIGHTY EIGHT &
NINETY EIGHT
BUICK LA SABRE, WILDCAT, &
ELECTRA '225

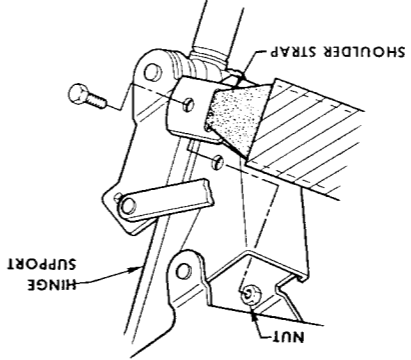

CHEVROLET CAMARO
PONTIAC FIREBIRD

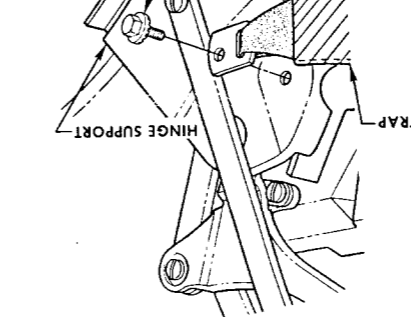

VIEW A
NO SHOULDER
1/2" 13 THREAD

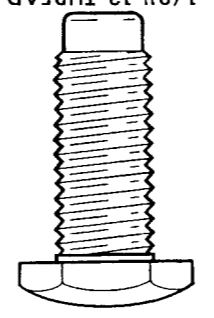

VIEW A
3/8" 16 THREAD

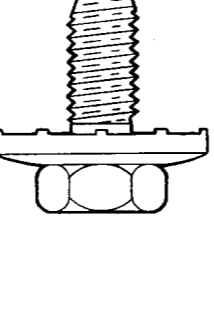

CHEVROLET CHEVETTE
PONTIAC TEMPEST, LEMANS & GTO
OLDSMOBILE '88, CUTLASS &
BUICK SKYLARK & GRAN SPORT

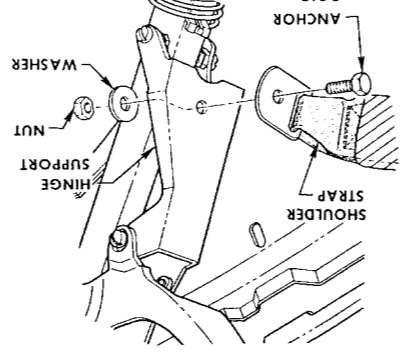

CHEVROLET COVAIR

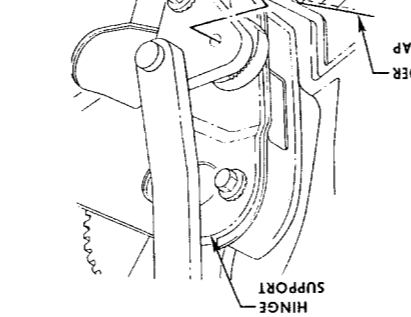

VIEW A
NO SHOULDER
1/2" 13 THREAD

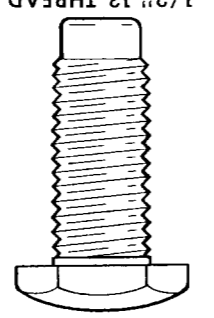

VIEW A
3/8" 16 THREAD

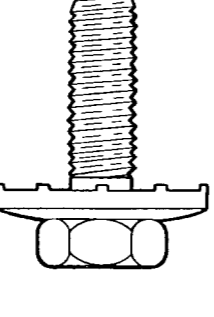

FLOOR ANCHORAGE

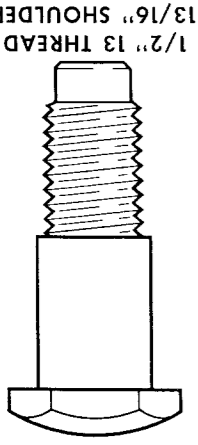
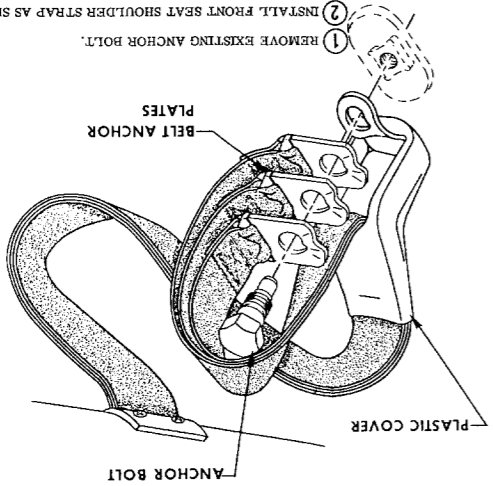

- REMOVE EXISTING ANCHOR BOLT.
- INSTALL FRONT SEAT SHOULDER STRAP AS SHOWN IN VIEW B.
- NOTE: CHECK POSITION OF FACTORY INSTALLED BELT ANCHORS AND INSTALL NEW BELT AND ANCHOR PLATES IN SAME POSITION. CARE MUST BE EXERCISED WHEN MAKING INSTALLATION THAT ALL BELT ANCHOR PLATES INTER-LOCK AS SHOWN.
- ON BUCKET TYPE SEAT REPLACE EXISTING ANCHOR BOLT THROUGH BELT ANCHOR PLATES AND SECURE TO FLOOR, ON BENCH TYPE SEAT USE NEW 1/2 INCH X 13 UNC - 24 BOLT WITH 13/16" SHOULDER PROVIDED.

NOTE: FOR INSTRUCTIONS ON REMOVAL AND INSTALLATION OF ALL SEAT CUSHIONS, SEAT BACKS AND TRIM PANELS NECESSARY TO PERFORM OPERATIONS DESCRIBED ON THIS SHEET, REFER TO 1969 COPY OF THE FISHER BODY SERVICE MANUAL AVAILABLE AT YOUR G.M. DEALER.

VIEW B

BUCKLE RETAINER

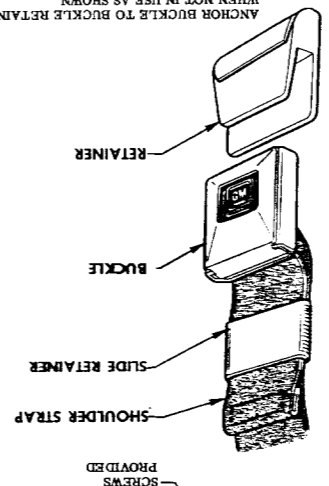
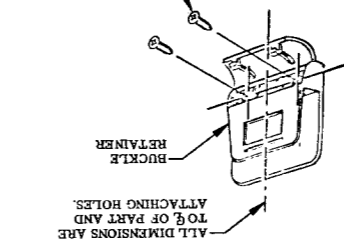

- NOTE-
- AND LOCATE THE STYLE AND DIMENSION FOR LOCATING THE RETAINER IN YOUR CAR.
 - DRILL TWO (2) 1/8" HOLES AND SECURE RETAINER TO BODY.

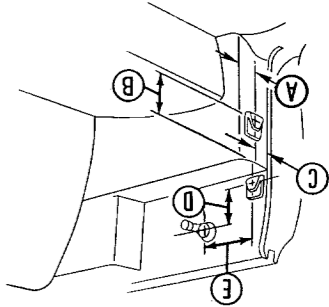

STYLES	DIMENSION				
	A	B	C	D	E
CHEVROLET CAMARO	6 1/2	8 1/2			
PONTIAC FIREBIRD	6 1/2	8 1/2			
CHEVROLET CHEVETTE	6 1/2	8 1/2			
PONTIAC TEMPEST, LEMANS & GTO	6 1/2	8 1/2			
OLDSMOBILE	6 1/2	8 1/2			
BUICK SKYLARK & GRAN SPORT	6 1/2	8 1/2			
CHEVROLET IMPALA	6 1/2	8 1/2			
PONTIAC CATALINA, BONNEVILLE & GRAND PRIX	6 1/2	8 1/2			
OLDSMOBILE EIGHTY EIGHT & NINETY EIGHT	6 1/2	8 1/2			
BUICK	6 1/2	8 1/2			
SKYLARK & GRAN SPORT	6 1/2	8 1/2			
CHEVROLET	6 1/2	8 1/2			
PONTIAC	6 1/2	8 1/2			
TEMPEST, LEMANS & GTO	6 1/2	8 1/2			
OLDSMOBILE	6 1/2	8 1/2			
F88, CUTLASS & 442	6 1/2	8 1/2			
BUICK	6 1/2	8 1/2			
SKYLARK & GRAN SPORT	6 1/2	8 1/2			
CHEVROLET	6 1/2	8 1/2			
IMPALA	6 1/2	8 1/2			
PONTIAC	6 1/2	8 1/2			
CATALINA, BONNEVILLE & GRAND PRIX	6 1/2	8 1/2			
OLDSMOBILE	6 1/2	8 1/2			
EIGHTY EIGHT & NINETY EIGHT	6 1/2	8 1/2			
BUICK	6 1/2	8 1/2			
LA SABRE, WILDCAT & ELECTRA '225	6 1/2	8 1/2			
CADILLAC	6 1/2	8 1/2			
DE VILLE	6 1/2	8 1/2			
CHEVROLET COVAIR MONZA	6 1/2	8 1/2			

BELT ADJUSTMENT

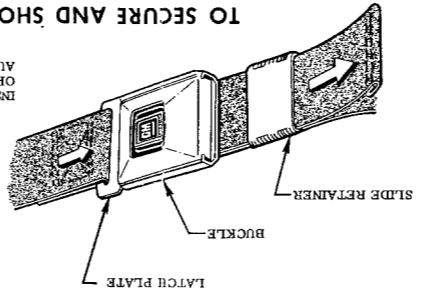

TO SECURE AND SHORTEN

INSERT LATCH PLATE INTO THE OPEN END OF BUCKLE UNTIL AN AUDIBLE SNAP IS HEARD.

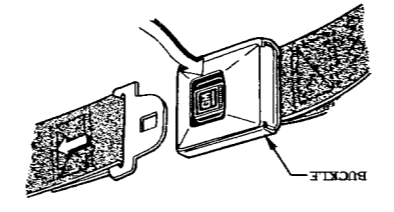

TO UNLATCH

TO RELEASE BELT, DEPRESS BUTTON ON BUCKLE.

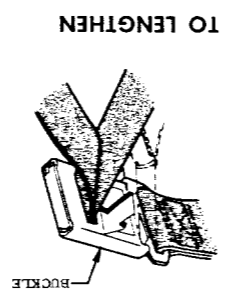

TO LENGTHEN

TO ENLARGE THE BELT, LEFT BUCKLE APPROXIMATELY 90 DEGREES TO THE WEBBING AND PULL ON BUCKLE TO DESIRED LENGTH.

GENERAL INFORMATION

- THIS UPPER TORSO RESTRAINT TO BE USED ONLY IN CONJUNCTION WITH A LAP BELT. NEVER USE THE SHOULDER STRAP ALONE.
- SHOULDER STRAPS NOT IN USE MUST BE ANCHORED BY INSERTING BUCKLE INTO RETAINER LOCATED ON BODY PILLAR TO PREVENT BUCKLE END LASHING ABOUT SHOULDER STRAPS ARE RECOMMENDED ONLY FOR PERSONS OVER 4 FEET 7 INCHES IN HEIGHT.
- PROPER USE AND CARE OF YOUR SHOULDER STRAPS AND SEAT BELTS WILL PROVIDE ADDED SECURITY TO DRIVER AND PASSENGERS.
- INSERT THE LATCH PLATE INTO THE OPEN END OF THE BUCKLE UNTIL AN AUDIBLE SNAP IS HEARD.
 - ADJUST BELT BY PULLING ON THE LOOSE END OF WEBBING PROTRUDING FROM THE BUCKLE. SEAT BELTS SHOULD BE ADJUSTED FIRMLY, LOW ON THE HIPS. SHOULDER STRAPS SHOULD HAVE SUFFICIENT SLACK TO ALLOW A HAND'S WIDTH TO BE INSERTED FREELY BETWEEN THE BELT AND CHEST.
 - TO ENLARGE THE BELT, TILT BUCKLE TO APPROXIMATELY 90 DEGREES TO THE WEBBING AND PULL ON BUCKLE TO DESIRED LENGTH.
 - KEEP SHARP EDGES AND DAMAGING OBJECTS AWAY FROM BELTS.
- NOTE: AVOID THE FOLLOWING CONDITIONS
- WEARING SEAT BELTS LOOSELY ON SHOULDER STRAPS SMUG
 - BLEACHING OR HE-DYEING WEAVING (CLEAN WITH A MILD SOAP SOLUTION AND WATER)
 - MORE THAN ONE PERSON PER BELT SET (SEAT & SHOULDER)
 - WEARING A TWISTED BELT

ATTENTION DEALERS

PLACE THIS INSTRUCTION SHEET IN GLOVE BOX AFTER BELT INSTALLATION.

8701739

FRONT & REAR SEAT SHOULDER STRAP INSTALLATION INSTRUCTIONS

FISHER BODY SERVICE MANUAL

1969

NOTE: LAP BELT MUST BE WORN WHEN USING A CHILDREN SEAT

DATE 6 27 79